

# DOUBLE DRUM GRIPPER- DGD-A

APPROX WEIGHT: 132.89 lbs.  
DOES NOT INCLUDE WEIGHT OF POWER OR PACKAGING!!!

\*\*\* ANY ADDITIONS, DELETIONS, OR OMISSIONS MUST BE CORRECTED ON THIS DRAWING AS THIS DRAWING WILL BE CONSIDERED ALL INCLUSIVE \*\*\*

ALL GRAPHICS PROVIDED ARE FOR REFERENCE ONLY. IF CERTAIN DIMENSIONS ARE CRITICAL PLEASE VERIFY THOSE DIMENSIONS WITH YOUR SALESPERSON

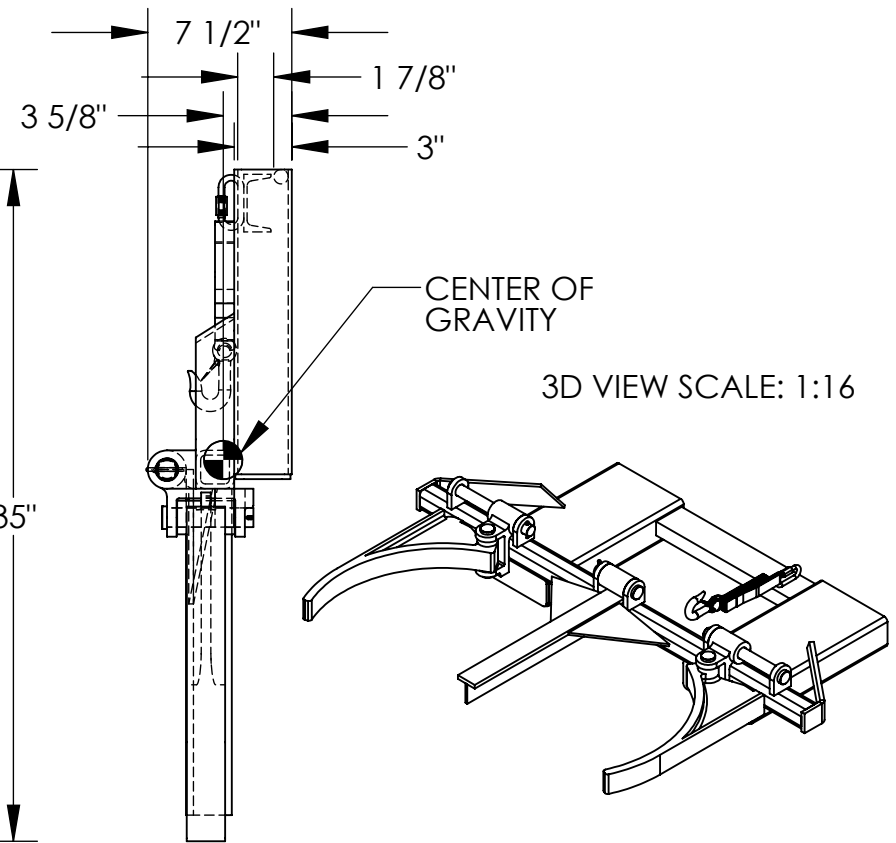
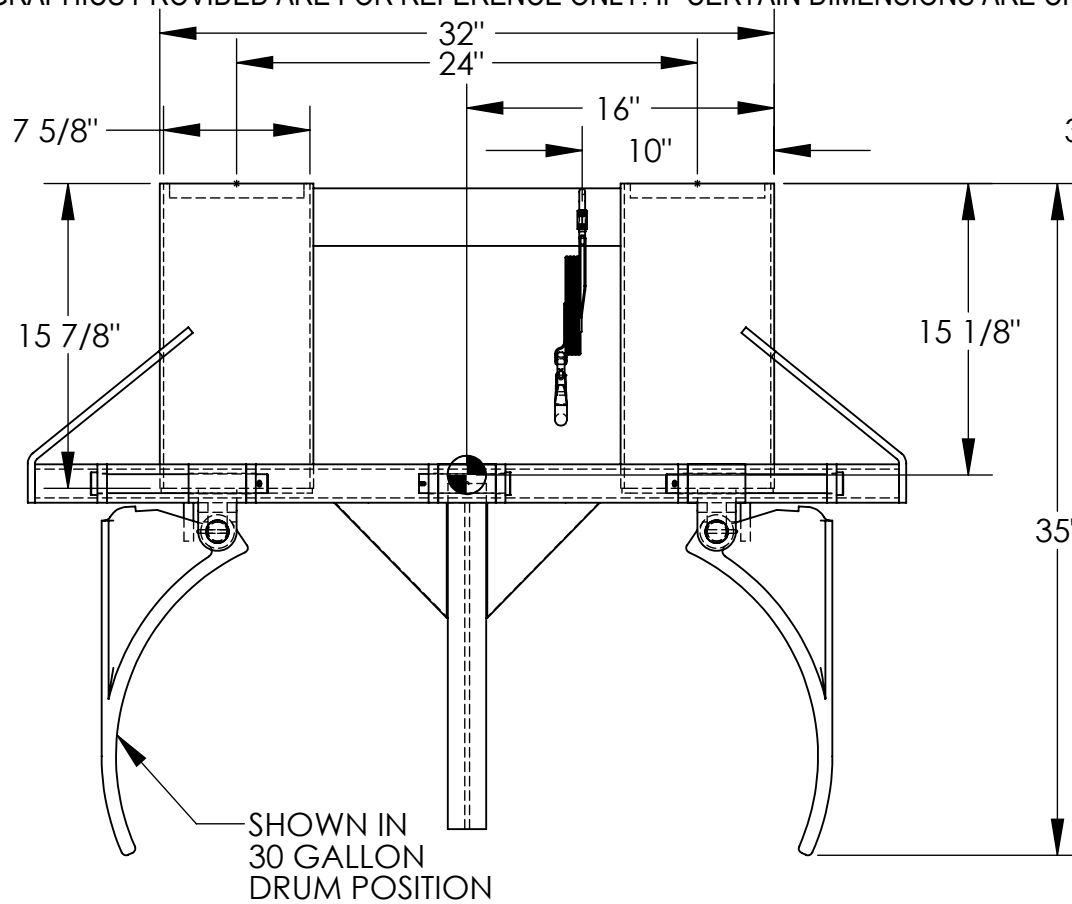

DIMENSION TOLERANCE  $\pm 1/4$ "

I, THE UNDERSIGNED, AGREE THAT THE PRODUCT AS REPRESENTED SATISFIES DESIGN AND DIMENSION REQUIREMENTS. I ALSO ACKNOWLEDGE MY DUTY TO CONFIRM PRODUCT AND INSTALLATION COMPLIANCE WITH ALL APPLICABLE FEDERAL, STATE AND LOCAL REGULATIONS AND STANDARDS.

**ANY MODIFIED UNITS ARE NON-RETURNABLE**

[ ] As drawn [ ] As marked

Signed: \_\_\_\_\_ Date: \_\_\_\_\_

Printed Name: \_\_\_\_\_

LEAD TIME WILL START UPON RECEIPT OF SIGNED APPROVAL DRAWING

APPROVAL

## STANDARD FEATURES

- MODEL NUMBER: DGD-A
- CAPACITY: 1,500 LBS.
- HOLDS 30 AND/OR 55 GALLON STEEL DRUMS
- FORK POCKET C-C = 24"
- FORK POCKET SIZE IS = 7 5/8" W x 1 7/8" H
- LOST LOAD IS 135 LBS. (APPROX)
- EFFECTIVE THICKNESS IS FORK LENGTH MINUS 16"
- TOUGH BAKED IN POWDER COAT BLUE FINISH

## SPECIAL FEATURES

NONE

FOR INTERNAL USE ONLY PROJECT SIGN OFF	
SALES	
ENG.	
FAB.	
POWER	

DISTRIBUTOR'S NAME:		P.O.#
VESTIL MANUFACTURING		X
W.O.#		X
DRAWN BY: KGY	DATE: 5/22/2005	SALES: X
REFERENCE: X	SCALE: 1:10	FILE NAME:
QUOTED LEAD TIME: X	QUOTE # X	09-007-087

APPROX. WEIGHT / LOST LOAD = 132.89 LBS. EACH  
MINIMUM EFFECTIVE THICKNESS IS: (USABLE FORK LENGTH - 16")  
DRUM GRIPPER DOES NOT CHANGE THE LOAD CENTER OF EXISTING FORK TRUCK.  
NEVER EXCEED LOAD CENTER RATING PER FORK TRUCK MANUFACTURER'S GUIDELINES.  
DO NOT USE THIS FORK TRUCK ATTACHMENT IF LOAD WILL EXCEED FORK TRUCK MANUFACTURER'S LOAD CENTER RATING.